

**HARTFORD**

<b>Style</b> .....	Hartford / SPA02
<b>Construction</b> .....	Rigid LVT
<b>Installation</b> .....	Click
<b>Thickness</b> .....	6mm
<b>Wear Layer</b> .....	20 mils
<b>Plank Size</b> .....	7.5" x 48"
<b>Sq Ft/Cartron</b> .....	17.3
<b>Attached Underlayment</b> .....	Yes
<b>Bevel</b> .....	Painted
<b>Plank Variation</b> .....	13 Unique Planks
<b>Warranty</b> .....	Lifetime Limited Residential / 15-YR Limited Commercial



			
<b>WATERPROOF</b>	<b>NO GAP GUARANTEE</b>	<b>EASY TO CLEAN</b>	<b>ALL PET PLUS</b>



JAMESTOWN | 865



NANTUCKET | 905

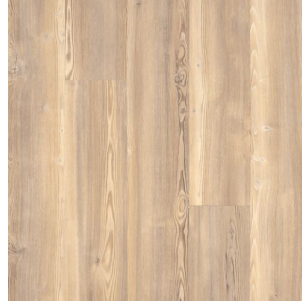

ABERDEEN | 320



ELLSWORTH | 253



HELENA | 916



SANTE FE | 367



SALEM | 835



YAKIMA | 960



CALEDONIA | 961



Waterproof



Approved for any level



Easy to clean



Repels stains and liquids



Dent Resistant



Scratch Protection



## TRANSITION AND TRIM PACKAGE

The RevoFit™ moisture resistant molding provides the functionality of a T-Molding and Reducer in a single, easy to install piece. The unique flexible zone design of the RevoFit™ track allows installation of the profile on either direction, thus eliminating the guess work out of positioning the trim.

## INSTALLS TWO DIFFERENT WAYS

### METHOD 1: T-MOLDING

As a T-Molding transition, the RevoFit™ is designed to accommodate the expansion gap between floors of equal heights ranging from 3-8mm.

### METHOD 2: REDUCER

As a Reducer transition, RevoFit™ is designed to accommodate the expansion gap of unequal height floors that have a thickness range of 3-8mm.

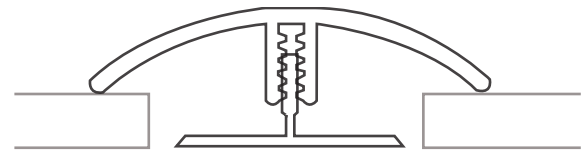

T-MOLDING

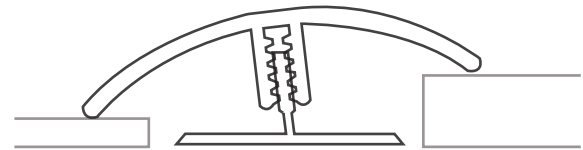

REDUCER

## SPECIFICATIONS

- Dimensions: 78.75" X 1.75"
- Core material: PVC
- Surface material: Highly wear resistant PVC
- Primary applications: Luxury Vinyl Flooring
- Patent Pending

## PRODUCT ITEM NUMBERS:

STYLE COLOR #	STYLE COLOR NAME	PART NUMBER
865	JAMESTOWN	V2IN1-04792
905	NANTUCKET	V2IN1-04720
320	ABERDEEN	V2IN1-04721
253	ELLSWORTH	V2IN1-04779
916	HELENA	V2IN1-04793
367	SANTE FE	V2IN1-04794
835	SALEM	V2IN1-04722
960	YAKIMA	V2IN1-04774
961	CALEDONIA	V2IN1-04780

## MOHAWK VINYL END MOLD TRANSITION PACKAGE

The Mohawk Vinyl End Mold is a moisture resistant molding that is suitable for transitions at doorways, sliding doors, against fireplaces, and when abutting joining rooms have floors of different heights.

### INSTALLATION METHOD

The Vinyl End Mold incorporates a universal track system with integrated shims that can be cutoff, or folded under. This allows the transition to work with vinyl floors ranging from 3mm to 8mm in height.

### SPECIFICATIONS

- Dimensions: 78.75" X 1.70"
- Core material: Rigid Vinyl
- Surface material: Highly wear resistant PVC
- Primary applications: Luxury Vinyl Flooring

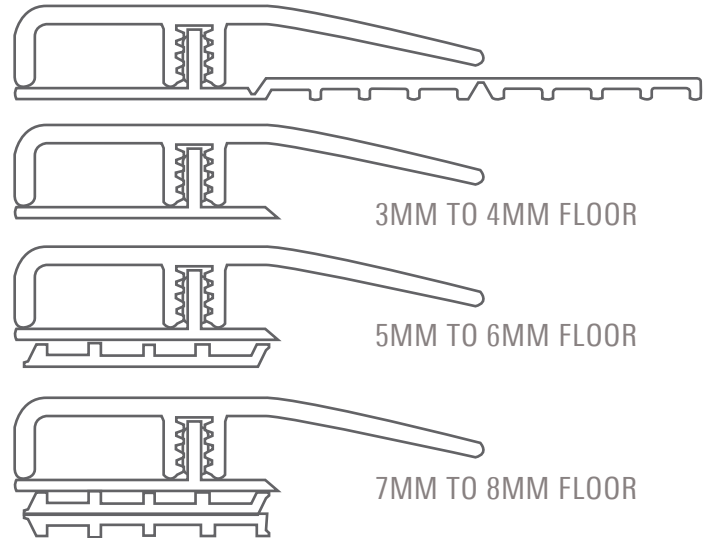

### PRODUCT ITEM NUMBERS:

STYLE COLOR #	STYLE COLOR NAME	PART NUMBER
865	JAMESTOWN	VEND-04792
905	NANTUCKET	VEND-04720
320	ABERDEEN	VEND-04721
253	ELLSWORTH	VEND-04779
916	HELENA	VEND-04793
367	SANTE FE	VEND-04794
835	SALEM	VEND-04722
960	YAKIMA	VEND-04774
961	CALEDONIA	VEND-04780

## MOHAWK VINYL FLUSH MOUNT STAIRNOSE TRANSITION PACKAGE

The Mohawk Flush Mount Stairnose is a moisture resistant molding that is suitable to finish stair installations of our rigid vinyl products. The Mohawk Vinyl Flush Mount Stairnose is designed to coordinate with both our flooring decors, and our specific locking systems.

### SPECIFICATIONS

- Dimensions: 94.5" x 4.5"
- Core material: Rigid Vinyl
- Surface material: Highly wear resistant PVC
- Primary applications: Luxury Vinyl Flooring

### PRODUCT ITEM NUMBERS:

STYLE COLOR #	STYLE COLOR NAME	PART NUMBER
865	JAMESTOWN	VFSN-04792
905	NANTUCKET	VFSN-04720
320	ABERDEEN	VFSN-04721
253	ELLSWORTH	VFSN-04779
916	HELENA	VFSN-04793
367	SANTE FE	VFSN-04794
835	SALEM	VFSN-04722
960	YAKIMA	VFSN-04774
961	CALEDONIA	VFSN-04780

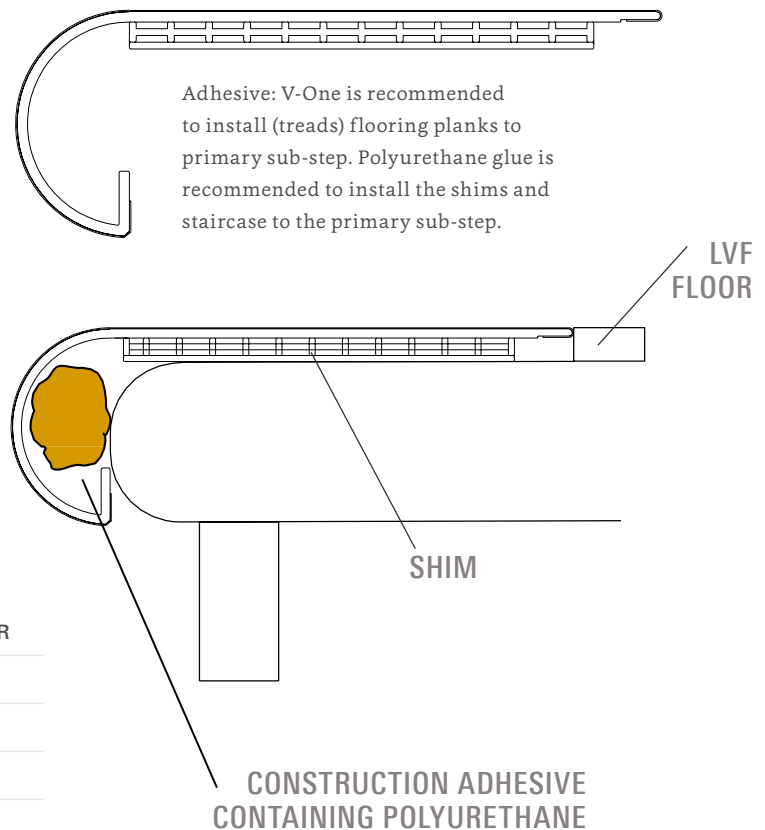

## MOHAWK VINYL QUARTER ROUND TRANSITION PACKAGE

The Mohawk Vinyl Quarter Round is a moisture proof molding that is suitable for transitioning to the wall or baseboards.

### INSTALLATION METHOD

The Vinyl Quarter Round can be finished nailed or glued into place. Do not nail or glue the vinyl Quarter Round to the flooring.

### SPECIFICATIONS

- Dimensions: 94.5" X .75"
- Core material: PVC
- Surface material: Highly wear resistant PVC
- Primary applications: Luxury Vinyl Flooring

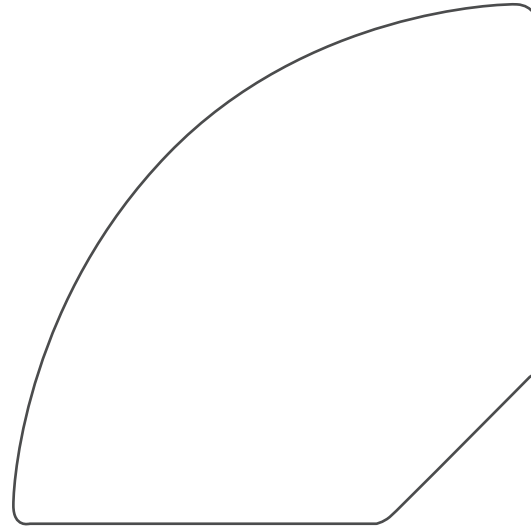

### PRODUCT ITEM NUMBERS:

STYLE COLOR #	STYLE COLOR NAME	PART NUMBER
865	JAMESTOWN	VQND-04792
905	NANTUCKET	VQND-04720
320	ABERDEEN	VQND-04721
253	ELLSWORTH	VQND-04779
916	HELENA	VQND-04793
367	SANTE FE	VQND-04794
835	SALEM	VQND-04722
960	YAKIMA	VQND-04774
961	CALEDONIA	VQND-04780