

DESOTO

Style Name	DeSoto / SPA01
Construction	Rigid LVT
Installation	Click
Thickness	6mm
Wear Layer	20 mils
Plank Size	7.5" x 48"
Sq Ft/Carton	17.3
Attached Underlayment	Yes
Bevel	Painted
Plank Variation	13 Unique Planks
Warranty	Lifetime Limited Residential/15-YR Limited Commercial Warranty



COLOR SHOWN: HANA



WATERPROOF



**NO GAP
GUARANTEE**



EASY TO CLEAN



ALL PET PLUS



HANA | 260



BANGOR | 222



JOPLIN | 565



SALINA | 850



AUGUSTINE | 950



BERKELEY | 830



DOVER | 880



HILLSBORO | 970



JONESBOROUGH | 999



100% Waterproof



Approved for any level



Easy to Clean



Repels stains and liquids



Dent Resistant



Scratch Protection



TRANSITION AND TRIM PACKAGE

The RevoFit™ moisture resistant molding provides the functionality of a T-Molding and Reducer in a single, easy to install piece. The unique flexible zone design of the RevoFit™ track allows installation of the profile on either direction, thus eliminating the guess work out of positioning the trim.

INSTALLS TWO DIFFERENT WAYS

METHOD 1: T-MOLDING

As a T-Molding transition, the RevoFit™ is designed to accommodate the expansion gap between floors of equal heights ranging from 3-8mm.

METHOD 2: REDUCER

As a Reducer transition, RevoFit™ is designed to accommodate the expansion gap of unequal height floors that have a thickness range of 3-8mm.

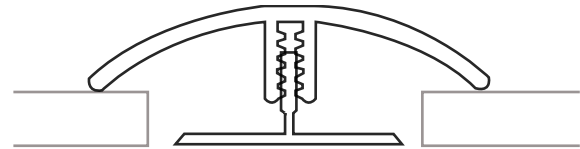

T-MOLDING

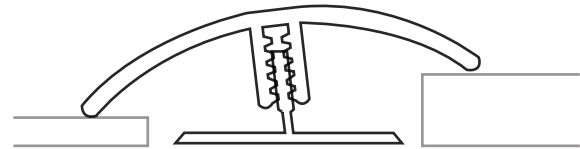

REDUCER

SPECIFICATIONS

- Dimensions: 78.75" X 1.75"
- Core material: PVC
- Surface material: Highly wear resistant PVC
- Primary applications: Luxury Vinyl Flooring
- Patent Pending

PRODUCT ITEM NUMBERS:

STYLE COLOR #	STYLE COLOR NAME	PART NUMBER
260	HANA	V2IN1-04783
222	BANGOR	V2IN1-04715
565	JOPLIN	V2IN1-04718
850	SALINA	V2IN1-04716
950	AUGUSTINE	V2IN1-04796
830	BERKELEY	V2IN1-04714
880	DOVER	V2IN1-04781
970	HILLSBORO	V2IN1-04782
999	JONESBOROUGH	V2IN1-04795

MOHAWK VINYL END MOLD TRANSITION PACKAGE

The Mohawk Vinyl End Mold is a moisture resistant molding that is suitable for transitions at doorways, sliding doors, against fireplaces, and when abutting joining rooms have floors of different heights.

INSTALLATION METHOD

The Vinyl End Mold incorporates a universal track system with integrated shims that can be cutoff, or folded under. This allows the transition to work with vinyl floors ranging from 3mm to 8mm in height.

SPECIFICATIONS

- Dimensions: 78.75" X 1.70"
- Core material: Rigid Vinyl
- Surface material: Highly wear resistant PVC
- Primary applications: Luxury Vinyl Flooring

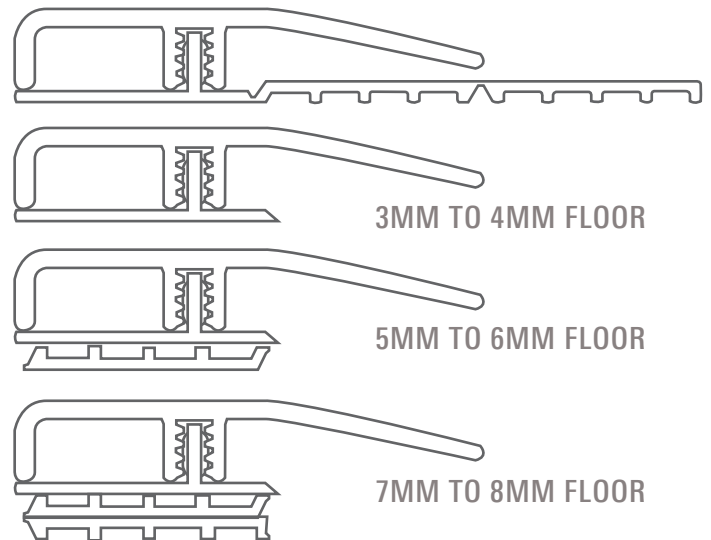

PRODUCT ITEM NUMBERS:

STYLE COLOR #	STYLE COLOR NAME	PART NUMBER
260	HANA	VEND-04783
222	BANGOR	VEND-04715
565	JOPLIN	VEND-04718
850	SALINA	VEND-04716
950	AUGUSTINE	VEND-04796
830	BERKELEY	VEND-04714
880	DOVER	VEND-04781
970	HILLSBORO	VEND-04782
999	JONESBOROUGH	VEND-04795

MOHAWK VINYL FLUSH MOUNT STAIRNOSE

The Mohawk Vinyl Flush Mount Stairnose is a moisture proof molding that is suitable to finish stair installations of vinyl luxury flooring. The Mohawk Vinyl Flush Mount Stairnose is designed for versatility and beauty. It is versatile as one molding can accommodate a wide range of floor thicknesses, from 2mm up to 7.5mm in thickness. The large width of the stairnose provides a more polished finished stair tread than competitive products. The longer length will accommodate more stairs than competitive products, and can be used on bull-nosed and squared-nosed stair installations.

SPECIFICATIONS

- Dimensions: 94.5" x 4.25" x 1.5"
- Core material: PVC
- Surface material: Highly wear resistant PVC
- Primary Applications: Luxury Vinyl Flooring
- ADA compliant

PRODUCT ITEM NUMBERS:

STYLE COLOR #	STYLE COLOR NAME	PART NUMBER
260	HANA	VFSN-04783
222	BANGOR	VFSN-04715
565	JOPLIN	VFSN-04718
850	SALINA	VFSN-04716
950	AUGUSTINE	VFSN-04796
830	BERKELEY	VFSN-04714
880	DOVER	VFSN-04781
970	HILLSBORO	VFSN-04782
999	JONESBOROUGH	VFSN-04795

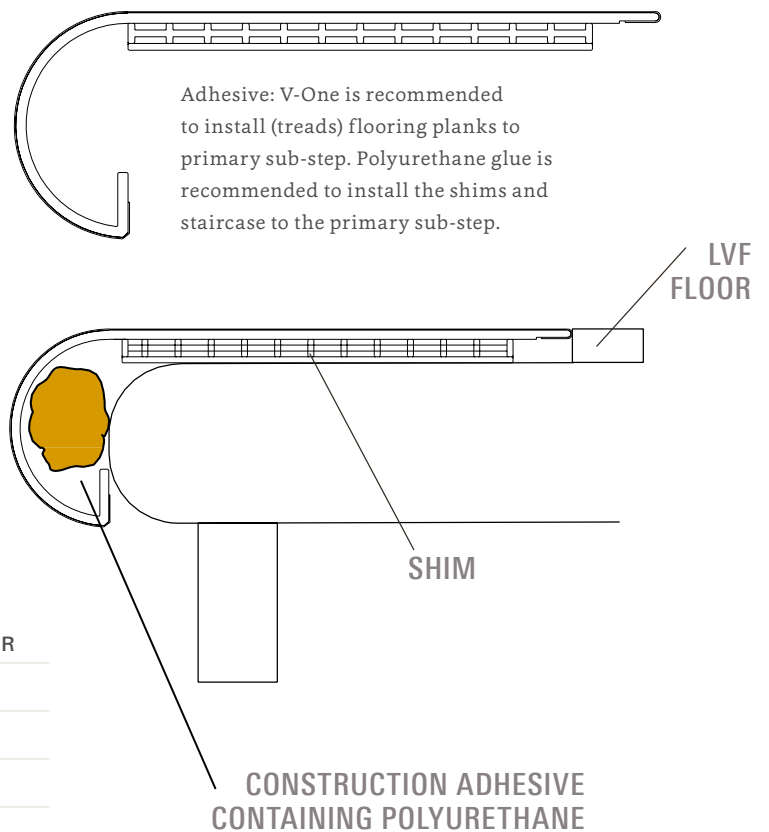

MOHAWK VINYL QUARTER ROUND TRANSITION PACKAGE

The Mohawk Vinyl Quarter Round is a moisture proof molding that is suitable for transitioning to the wall or baseboards.

INSTALLATION METHOD

The Vinyl Quarter Round can be finished nailed or glued into place. Do not nail or glue the vinyl Quarter Round to the flooring.

SPECIFICATIONS

- Dimensions: 94.5" X .75"
- Core material: PVC
- Surface material: Highly wear resistant PVC
- Primary applications: Luxury Vinyl Flooring

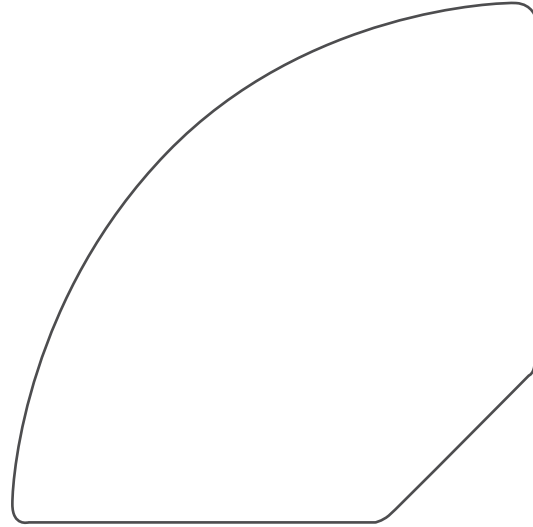

PRODUCT ITEM NUMBERS:

STYLE COLOR #	STYLE COLOR NAME	PART NUMBER
260	HANA	VQND-04783
222	BANGOR	VQND-04715
565	JOPLIN	VQND-04718
850	SALINA	VQND-04716
950	AUGUSTINE	VQND-04796
830	BERKELEY	VQND-04714
880	DOVER	VQND-04781
970	HILLSBORO	VQND-04782
999	JONESBOROUGH	VQND-04795